

# **PARTS MANUAL**

---

**T5Z (A476)  
T7Z (A477)**

**CUSTOMER EDITION**

---

***HYSTER***



**SECTIONS**

|          |                                  |
|----------|----------------------------------|
| <b>1</b> | <b>FRAME/DRIVE UNIT</b>          |
| <b>2</b> | <b>ELECTRICAL SYSTEM</b>         |
| <b>3</b> | <b>STEER HANDLE/BRAKE SYSTEM</b> |
| <b>4</b> | <b>REAR AXLE AND LOAD WHEELS</b> |
| <b>5</b> | <b>OPTIONS</b>                   |
| <b>6</b> | <b>NUMERICAL INDEX</b>           |

This Parts Manual is divided into 6 major sections which are listed above. Quick reference to these sections can be made by placing the right thumb on the tab of the desired section, bending the book back and thumbing the pages to the corresponding tab.



**Thanks very much for your reading,  
Want to get more information,  
Please click here, Then get the complete  
manual**

**JustClickHere** 

**NOTE:**

**If there is no response to click on the link above,  
please download the PDF document first, and then  
click on it.**

**Have any questions please write to me:  
[admin@servicemanualperfect.com](mailto:admin@servicemanualperfect.com)**

**TABLE OF CONTENTS**

| <b>DESCRIPTION</b>                    | <b>PAGE</b> |
|---------------------------------------|-------------|
| <b>B</b>                              |             |
| BACKPAD                               |             |
| INTERMEDIATE .....                    | 5-8         |
| BATTERY CONNECTOR .....               | 2-12        |
| BATTERY RETENTION .....               | 1-5         |
| BATTERY ROLLERS OPTION .....          | 5-4         |
| BATTERY SPACER .....                  | 5-6         |
| BRAKE ASSEMBLY                        |             |
| A476 .....                            | 3-12        |
| A477 .....                            | 3-13        |
| <b>C</b>                              |             |
| CONTROL PANEL ASSEMBLY                |             |
| ARCTIC .....                          | 2-2         |
| CONVENIENCE TRAY .....                | 5-10        |
| COVERS AND FLOORMATS .....            | 1-4         |
| <b>D</b>                              |             |
| DIAGNOSTIC HANDSET .....              | 5-12        |
| <b>E</b>                              |             |
| ELECTRICAL ASSEMBLY .....             | 2-6         |
| <b>F</b>                              |             |
| FOOT SWITCH ASSEMBLY .....            | 2-18        |
| <b>H</b>                              |             |
| HAND BRAKE ASSEMBLY .....             | 3-10        |
| <b>J</b>                              |             |
| JUMPER WIRE ASSEMBLY                  |             |
| PARKING BRAKE SWITCH .....            | 2-22        |
| <b>L</b>                              |             |
| LABELS AND MANUAL .....               | 1-2         |
| <b>M</b>                              |             |
| MASTER DRIVE UNIT                     |             |
| A476 .....                            | 1-8         |
| A477 .....                            | 1-10        |
| MASTER DRIVE UNIT ASSEMBLY            |             |
| A476 .....                            | 1-12        |
| A477 (→ S/N A477N01512B) .....        | 1-16        |
| A477 (S/N A477N01513B ↔ 6/2008) ..... | 1-20        |
| A477 (6/2008 →) .....                 | 1-24        |
| <b>R</b>                              |             |
| REAR AXLE AND LOAD WHEEL .....        | 4-2         |
| <b>S</b>                              |             |
| STEER HANDLE ARM ASSEMBLY .....       | 3-2         |

**TABLE OF CONTENTS (continued)**

| <b>DESCRIPTION</b>               | <b>PAGE</b> |
|----------------------------------|-------------|
| STEER HANDLE HEAD ASSEMBLY ..... | 3-4         |
| STEER HEAD HEATER                |             |
| COLD STORAGE ONLY .....          | 5-2         |
| SWITCH ASSEMBLY                  |             |
| DIRECTION .....                  | 3-8         |
| <b>T</b>                         |             |
| TOWING COUPLER .....             | 1-6         |
| TRACTION MOTOR                   |             |
| A476 .....                       | 2-14        |
| A477 .....                       | 2-16        |
| <b>W</b>                         |             |
| WIRE HARNESS                     |             |
| FOOT SWITCH .....                | 2-21        |
| MAIN TRUCK .....                 | 2-19        |
| PUSH BUTTON .....                | 3-15        |
| STEER HANDLE .....               | 2-20        |
| STEER HANDLE CABLE .....         | 3-14        |

**ABBREVIATIONS QUICK REFERENCE SHEET**

Listed below are abbreviations used in parts manuals to denote the following expressions:

| <b>TERM</b> | <b>DEFINITION</b>                                   | <b>TERM</b> | <b>DEFINITION</b>                  |
|-------------|---|-------------|------------------------------------|
| Amp         | Amperes   | FRE         | Freezer Environment                |
| AR          | As Required   | in.         | inches                             |
| BDI         | Battery Discharge Indicators                        | LPG         | Liquefied Petroleum Gas            |
| BWI         | Brush Wear Indicator                                | MAP         | Manifold Absolute Pressure         |
| CE          | Communicator End                                    | mm          | millimeters                        |
| CRE         | Corrosive Environment                               | MSTS        | Microprocessor Spark Timing System |
| D/B         | Date Break  | NPT         | National Pipe Threads              |
| dbA         | Decibel "A" Scale                                   | O/S         | Oversize                           |
| DE          | Drive End   | PTO         | Power Take Off                     |
| ECH         | Empty Container Handler                             | RPM         | Revolutions per Minute             |
| ECH-3       | Empty Container Handler - 3 High Stacking           | S/N         | Serial Number                      |
| ECH-4       | Empty Container Handler - 4 High Stacking           | TMM         | Truck Management Module            |
| ECH-5       | Empty Container Handler - 5 High Stacking           | UL Type D   | Diesel-Powered Safety Rating       |
| ECH-6       | Empty Container Handler - 6 High Stacking           | UL Type DS  | Diesel-Powered Safety Rating       |
| ECH-7       | Empty Container Handler - 7 High Stacking           | UL Type E   | Battery-Powered Safety Rating      |
| ECM         | Electronic Control Module                           | UL Type EE  | Battery-Powered Safety Rating      |
| ECN         | Engineering Change Notice                           | UL Type ES  | Battery-Powered Safety Rating      |
| EEPROM      | Electrically Erasable Programmable Read Only Memory | UL Type G   | Gasoline-Powered Safety Rating     |
| EPA         | US Environmental Protection Agency                  | UL Type GS  | Gasoline-Powered Safety Rating     |
| EPROM       | Electrically Programmable Read Only Memory          | UL Type LP  | Gas-Powered Safety Rating          |
|             |   | UL Type LPS | LP Gas-Powered Safety Rating       |
|             |   | U/S         | Undersize                          |
|             |   | UL          | Underwriters Laboratory            |
|             |   | V           | Volts                              |



## HOW TO USE THE ILLUSTRATED PARTS MANUAL

This parts manual describes and illustrates assemblies, subassemblies, and detail parts needed for service replacement.

The different constructions are indicated by keys and footnotes. The callouts correspond to descriptions found on the next page.

**HYSTER** UNIT CODE D001 NORTH AMERICA 06/2001

**TABLE OF CONTENTS**

| DESCRIPTION  | PAGE |
|--|------|
| AIR INTAKE AND FILTER DIESEL (⇒ D/B 11/98)         | 3-22 |
| AIR INTAKE AND FILTER DIESEL (D/B 11/96 ⇒)         |      |
| AIR INTAKE AND FILTER GASOLINE AND LPG             |      |
| ALTERNATOR GASOLINE, LPG, AND DIESEL               |      |
| ALTERNATOR TYPES GS, LPS, AND DS                   |      |
| AUXILIARY FUNCTION TUBE TWO AND THREE STAGE FULL F |      |

**SECTION 13 NUMERICAL INDEX**

| PART NO. | PAGE NO. | ITEM NO. | PART NO. | PAGE NO. | ITEM NO. | PART NO. | PAGE NO. | ITEM NO. | PART NO. | PAGE NO. | ITEM NO. |
|----------|----------|----------|----------|----------|----------|----------|----------|----------|----------|----------|----------|
| 142      | 3-4      | 19       | 10-13    | 25       |          | 11-27    | 29       | 12-31    | 12       |          |          |
| 12445    | 3-32     | 19       | 10-17    | 6        |          | 11-31    | 25       | 16719    | 3-36     | 5        |          |
|          | 3-34     | 1        | 10-27    | 11       |          | 11-32    | 37       | 16751    | 3-16     | 27       |          |
|          |          |          | 11-11    | 6        | 16485    | 8-4      | 29       | 16849    | 3-34     | 21       |          |
|          |          |          | 12-21    | 11       |          | 8-4      | 45       |          | 3-38     | 20       |          |
|          |          |          | 14       | 13       |          | 8-8      | 34       | 16863    | 3-28     | 17       |          |
|          |          |          | 12       | 6        |          | 9-7      | 9        | 16865    | 3-6      | 18       |          |
|          |          |          | 3        | 17       |          | 9-7      | 19       |          | 4-27     | 41       |          |
|          |          |          | 9        | 10       |          | 9-11     | 9        | 16882    | 9-7      | 30       |          |
|          |          |          | 23       | 46       |          | 9-11     | 17       |          | 9-11     | 27       |          |
|          |          |          | 27       | 46       |          | 10-9     | 21       |          | 10-10    | 36       |          |
|          |          |          | 26       | 14       |          | 10-9     | 28       |          | 10-13    | 32       |          |
|          |          |          | 28       | 14       |          | 10-13    | 16       |          | 11-7     | 24       |          |
|          |          |          | 50       | 14       |          | 11-7     | 19       |          | 11-9     | 17       |          |

**SECTIONS**

- 1
- 2
- 3
- 4
- 5 BRAKE/ACC
- 6
- 7 MAST-TWO STAG
- 8 MAST-THREE ST
- 9 MAST-TWO ST
- 10
- 11

**TRANSMISSION HOUSING** ⇒ S/N D001H-2628

KEY:  
A: Diesel  
B: Gasoline and LPG

| ITEM | PART NO. | DESCRIPTION                         | QTY |    |
|------|----------|-------------------------------------|-----|----|
|      |          |                                     | A   | B  |
| 1    | 202547   | Transmission                        | 1   | 1  |
| 2    | 2023329  | Transmission                        | 1   | 1  |
| 3    | 2021670  | Case                                | 2   | 2  |
| 4    | 2023418  | Bearing Cap                         | 4   | 4  |
| 5    | 296429   | Washer                              | 4   | 4  |
| 6    | 293947   | Bolt                                | 1   | 1  |
| 7    | 2021390  | Cover                               | 2   | 2  |
| 8    | 1371656  | Colter Pin                          | 4   | 4  |
| 9    | 2021915  | O-Ring                              | 1   | 1  |
| 10   | 2021329  | Plug                                | 4   | 4  |
| 11   | 2021675  | Housing                             | 22  | 22 |
| 12   | 2021336  | Pin                                 | 39  | 39 |
| 13   | 287860   | Bolt                                | 1   | 1  |
| 14   | 292682   | Lockwasher                          | 1   | 1  |
| 15   | 2021345  | Hydraulic Pump<br>⇒ Figure 5-3      | 1   | 1  |
| 16   | 214364   | Gasket                              | 1   | 1  |
| 17   | 296418   | Bolt                                | 8   | 8  |
| 18   | 2021388  | Washer                              | 1   | 1  |
| 19   | 2021389  | Temperature Switch                  | 1   | 1  |
| 20   | 2021383  | Breather                            | 9   | 9  |
| 21   | 292515   | Dipstick                            | 9   | 9  |
| 22   | 136692   | Bolt                                | 2   | 2  |
| 23   | 292527   | Nut                                 | 3   | 3  |
| 24   | 292531   | Bolt                                | 3   | 2  |
| 25   | 292583   | Capcrew                             | 4   | 4  |
| 26   | 293637   | Lockwasher                          | 4   | 4  |
|      | 296420   | Bolt                                | 4   | 4  |
|      | 296420   | Washer                              | 1   | 1  |
|      | 996403   | Transmission Kit (Includes Item 7)  | 1   | 1  |
|      | 996405   | Transmission Kit (Includes Item 14) | 1   | 1  |

This Parts Manual is divided into 11 major sections which are listed above. Quick be made by placing the right thumb on the tab of the desired section, bending the pages to the corresponding tab.

©Copy Right Date HYSTER COMPANY See Service Manual for service procedures. 5-15

HP990004

## HOW TO FIND THE DESIRED PART NUMBER

### WHEN THE PART NUMBER AND THE NEXT HIGHER ASSEMBLY IS NOT KNOWN:

1. Determine the function and application of the part required. Turn to the Sections Page. Choose the general area of reference most likely to include the part.
2. Turn to the section you chose. Use the Section Table of Contents to determine the assembly which would normally contain the part required. Then locate the part on the assembly breakdown page.

### WHEN THE PART NUMBER IS NOT KNOWN AND THE NEXT HIGHER ASSEMBLY IS KNOWN:

3. Determine the assembly the required part is used on. Turn to the Table of Contents (Page i).
4. Locate the assembly the required part is used on and turn to the page indicated for that assembly. Then locate the part on the assembly breakdown page.

### WHEN THE PART NUMBER IS KNOWN:

5. Use the Numerical Index (Page 6-1) to find the part number. Turn to the page listed and locate the part as indicated by the item number.

### GENERAL:

The assembly breakdowns include part numbers, descriptions, quantities required, keys and footnotes to help in selecting correct parts.

6. Parts Supersession Information. Part numbers that have this history will be displayed in the parts list in the order that they were superseded (from oldest to newest). The superseded part numbers will be shown with a line through them.

Five periods in the PART NO. column (. . . . .) indicate that the part is either *Not Serviced Separately* or there is a reference to another figure. A figure reference is denoted by a pointing hand followed by a figure number in the DESCRIPTION column (☞ Figure 10)

7. Keys are used to show two or more similar assemblies, RH and LH assembly parts, etc. Select the appropriate key, "A", "B", "C", "D", or "E" and the corresponding quantity column to find the required parts. Two periods in the QTY column (..) indicate that the part is not used for that assembly.
8. Indented descriptions under the DESCRIPTION column are used to indicate assemblies and

subparts of assemblies. In the example on the previous page, *BEARING CAP* (Item 2) is a subpart of the major assembly *CASE*.

9. Quantities shown are for one assembly. The quantities of the subpart *BEARING CAP* are indicated as two and two. This means two per *CASE* assembly.
10. Serial number breaks identify the most current parts information and are shown as follows:
  - **S/N D001H2628**  
Indicates last serial number affected.
  - S/N D001H2629** →  
Indicates the first serial number affected.
  - S/N D001H1553** ↔ **S/N D001H3291**  
Indicates a range of serial numbers affected.

ECN numbers for pending serial numbers are shown to allow for the inclusion of the most current parts information and are identified as follows:

→ **S/N Pending Per ECN 63243**

Indicates a pending serial number for last unit affected.

**S/N Pending Per ECN 63243** →

Indicates a pending serial number for first unit affected.

Date breaks are used to indicate when a change occurred but a subsequent serial number break was not recorded. This is an arbitrary date usually based on the ECN release and are identified as follows:

→ **D/B 3/00**

Indicates that a change occurred sometime within that month for the item affected.

**D/B 3/00** →

Indicates that a change occurred sometime within that month for the item affected.

**D/B 3/00** ↔ **D/B 4/00**

Indicates a range of production dates of the item affected.

Contact your local dealer for Hyster lift trucks for serial number information for items with a ECN or a date break.

### ORDERING PARTS:

When ordering replacement parts, give the unit serial number, part number, name of part and quantity required.

For any further information on parts, service, or ordering, consult your local dealer for Hyster lift trucks.

## IDENTIFICATION OF TRUCK SERIAL NUMBERS

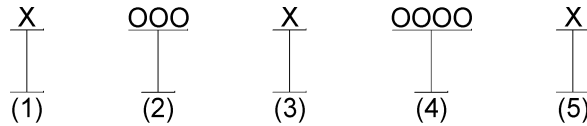

- (1) and (2) The first letter and three numbers indicate the truck unit code.
- (3) The second letter indicates the plant of manufacture.
- (4) The four or five digit number indicates the production sequence number of the truck.
- (5) The final letter indicates the year of manufacture starting with "A" in 1957, 1980, and 2003. The letters "I", "O", and "Q" will not be used.

For pending serial numbers contact your local dealer for Hyster lift trucks.

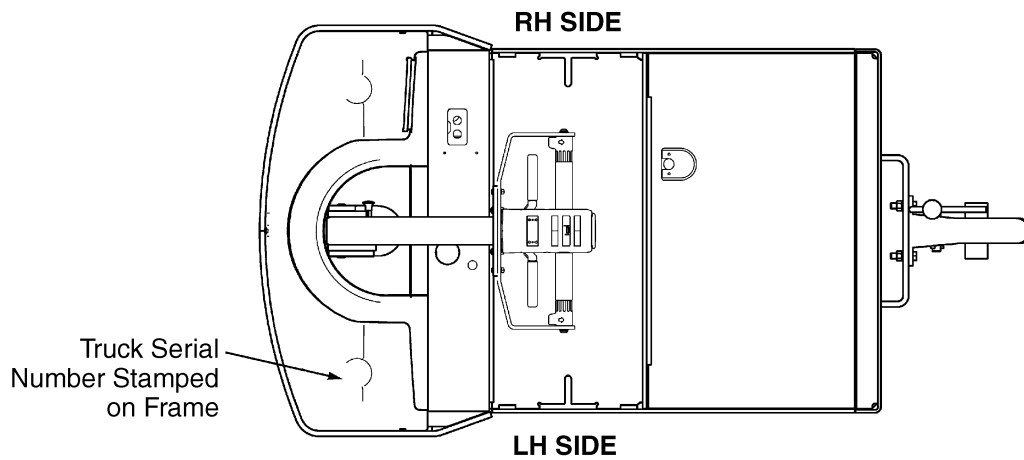

BP990004

Parts referred to in this book as right or left hand parts are in accordance with the illustration above.

**PUBLICATIONS**

Every new lift truck is provided with an OPERATING MANUAL. This manual has information that the operator must know for inspection and operation of the lift truck.

SERVICE MAINTENANCE MANUALS, which provide service and overhaul procedures, and PARTS

MANUALS with complete replacement part identification, are available at a nominal fee from your Hyster dealer to assist users in effectively maintaining Hyster lift trucks in a safe, useful condition. See the list below for information on ordering specific publications for this model lift truck.

| PUBLICATION                    | HYSTER PART NUMBER |
|--------------------------------|--------------------|
| Operating Manual.....          | 1524191            |
| Service Manual (Complete)..... | 1524194            |
| Parts Manual.....              | 1524193            |



1

FRAME/DRIVE UNIT



## SECTION 1 FRAME/DRIVE UNIT

| DESCRIPTION                           | PAGE |
|---------------------------------------|------|
| BATTERY RETENTION .....               | 1-5  |
| COVERS AND FLOORMATS .....            | 1-4  |
| LABELS AND MANUAL .....               | 1-2  |
| MASTER DRIVE UNIT                     |      |
| A476 .....                            | 1-8  |
| A477 .....                            | 1-10 |
| MASTER DRIVE UNIT ASSEMBLY            |      |
| A476 .....                            | 1-12 |
| A477 (→ S/N A477N01512B) .....        | 1-16 |
| A477 (S/N A477N01513B ↔ 6/2008) ..... | 1-20 |
| A477 (6/2008 →) .....                 | 1-24 |
| TOWING COUPLER .....                  | 1-6  |



## LABELS AND MANUAL (FIGURE 1-1)

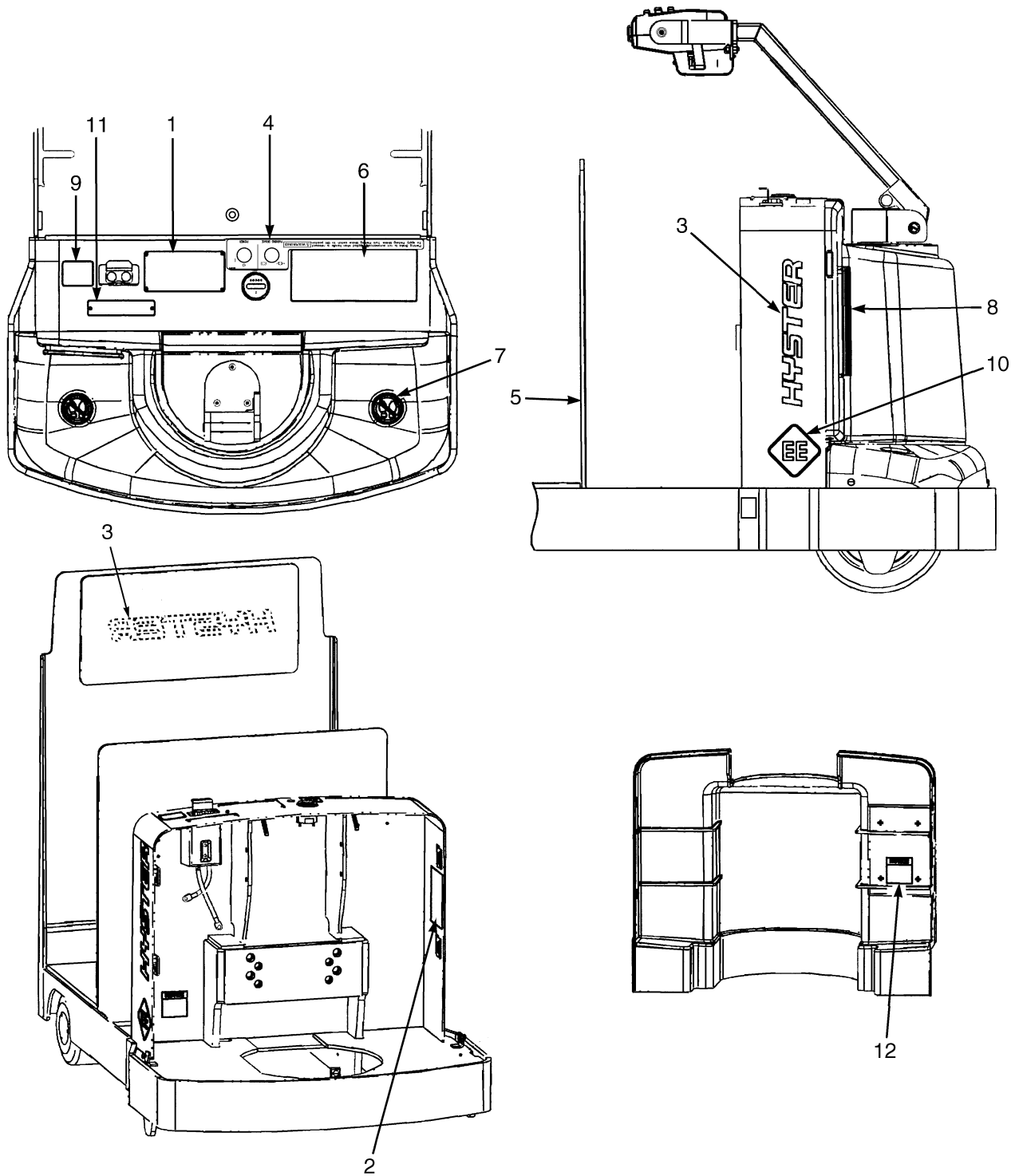

HP260024

**LABELS AND MANUAL**

| ITEM | PART NO.         | DESCRIPTION  | QTY |
|------|------------------|--|-----|
| 1    | . . . . .        | Nameplate (Contact Your Dealer) .....                    | 1   |
| 1    | 389688           | Nameplate Cover .....                                    | 1   |
| 1    | 2307400          | Rivet .....  | 4   |
| 2    | 1534660          | Label (Patents and Trademarks) .....                     | 1   |
| 3    | 1529042          | Label (Hyster) .....                                     | 3   |
| 4    | 2063906          | Label (Power and Parking Brake) .....                    | 1   |
| 5    | 2307359          | Label (High Speed) .....                                 | 1   |
| 6    | 2053014          | Label (Warning) .....                                    | 1   |
| 7    | 2053454          | Label (No Step) .....                                    | 2   |
| 8    | 1524191          | Operator Manual .....                                    | 1   |
| 9    | <b>b</b> 2044484 | Label (Battery Discharge Notice - Flooded Battery) ..... | 1   |
| 10   | <b>a</b> 196927  | Label (UL Type EE) .....                                 | 1   |
| 11   | <b>a</b> 325956  | U.L. Plate (U.L. Inspection-Type EE) .....               | 1   |

**FOOTNOTES:****a** "EE" Construction**b** BDI Option

## COVERS AND FLOORMATS (FIGURE 1-2)

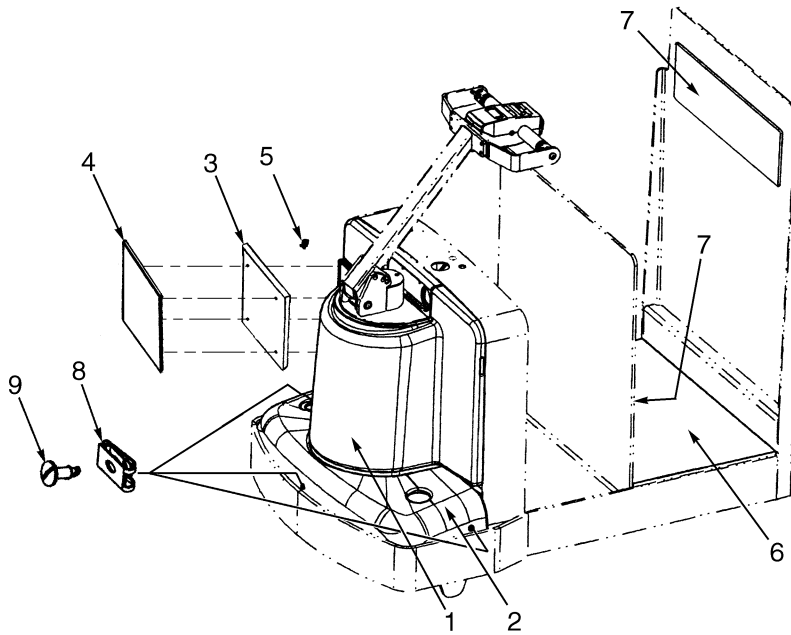

BP260007

| ITEM | PART NO. | DESCRIPTION                    | QTY |
|------|----------|--------------------------------|-----|
| 1    | 1468389  | Cover .....                    | 1   |
| 2    | 2054533  | Cover .....                    | 1   |
| 3    | 335989   | Information Case .....         | 1   |
| 4    | 335991   | Cover (Information Case) ..... | 1   |
| 5    | 2040664  | Rivet .....                    | 4   |
| 6    | 2059897  | Floormat .....                 | 1   |
| 7    | 2309789  | Pad .....                      | 2   |
| 8    | 2034382  | Clip .....                     | 3   |
| 9    | 2034380  | Screw .....                    | 3   |

**BATTERY RETENTION (FIGURE 1-3)**

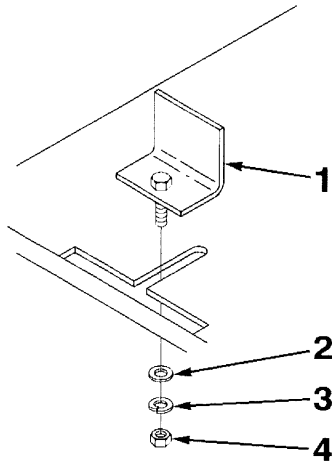

BP260003

| ITEM | PART NO. | DESCRIPTION               | QTY |
|------|----------|---------------------------|-----|
| 1    | 2034556  | Bracket (With Stud) ..... | 2   |
| 2    | 15178    | Washer .....              | 2   |
| 3    | 15158    | Washer .....              | 2   |
| 4    | 221712   | Nut .....                 | 2   |